

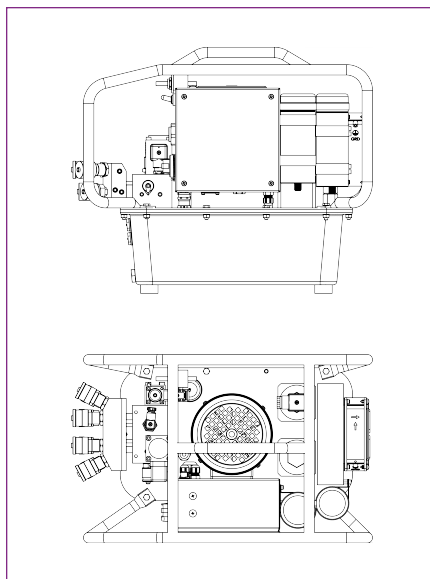

## VECTOR

The world's most advanced hydraulic power pack, the Vector Pump stands alone as the fastest fully automatic Hydraulic Power System thanks to its 3-stage high-speed flow motor. Gauge-free operation allows the operator to simply select the HYTORC tool they are using and the desired torque on the remote. As the first pump to offer LCD pendant control and automated regulation, HYTORC Vector Pumps are fully upgradeable and more intuitive than ever. Push the button and let the pump to do all the work.



### PUMP SPECIFICATIONS AND FEATURES

<b>Power</b>	115v (20 Amp) / 230v (10 Amp) / 400v (6 Amp)
<b>Data Recording</b>	Yes
<b>Gauge</b>	(Not necessary but can be attached to a process connection on the side of the valve block.)
<b>Reservoir Capacity</b>	2 gals. / 7,5 l
<b>Stages</b>	3
<b>Weight</b>	79 lbs. / 35.8 kg
<b>Maximum Oil Flow Rate*</b>	620 cu. in./min. / (10 l/min.)
<b>Oil Cooler</b>	Yes
<b>Protective Caging</b>	Yes
<b>15' Remote Control</b>	Yes
<b>15' Twin Line Steel Braided Hydraulic Hose</b>	Yes

\* Maximum Oil Flow Rate is dependent on voltage: 230v and 400v have a higher flow rate.

# HYTORC

**Headquarters:**  
333 Route 17 N., Mahwah, NJ 07430  
+1-201-512-9500

**Email:**  
info@hytorc.com

**Phone:**  
1-800-FOR-HYTORC

**Online:**  
hytorc.com